

固定螺纹管接头式热电偶 Joint type thermocouple of fixed thread pipe



型号 Model	分度号 Graduation	测温范围 °C Range of temperature measurement °C	连接尺寸 Connection size	保护管材质 Material for protective tube	规格 Specification	
					d	L
WRM-82 WRM ₂ -82	N	0~1100	M20×1.5	0Cr25Ni20	Φ3 Φ4 Φ5 Φ6 Φ8	245 270 295 345 395 445 545 645 745 899 1149
WRM-82A WRM ₂ -82A			NPT1/2			
WRN-82 WRN ₂ -82	K		M20×1.5	1Cr18Ni9Ti		
WRN-82A WRN ₂ -82A			NPT1/2			
WRE-82 WRE ₂ -82	E	0~700	M20×1.5	1Cr18Ni9Ti		
WRE-82A WRE ₂ -82A			NPT1/2			
WRC-82 WRC ₂ -82	T	0~350	M20×1.5	1Cr18Ni9Ti		
WRC-82A WRC ₂ -82A			NPT1/2			
WRF-82 WRF ₂ -82	J	0~600	M20×1.5	1Cr18Ni9Ti		
WRF-82A WRF ₂ -82A			NPT1/2			

- 1) 型号82、82A为防喷式，防护等级IP65；
- 2) 型号83、83A为防水式，防护等级IP55，其它参数同82、82A；
- 3) 如无特殊之约定，L 仅为参考尺寸，热电偶插入深度应为热安装套管U尺寸；
- 4) 热安装套管形式详见P119。

- 1) Model 82 and 82A are anti-spring type with the protective grade being IP65.
- 2) Model 83 and 83A are waterproof type with the protective grade being IP55. Other parameters are the same as model 82 and 82A.
- 3) If there is no special agreement, L is only the reference size. The insertion depth of thermocouple should be the size of thermal installation sleeve U.
- 4) The form of thermal mounting sleeve is shown in P119.

安装形式 Installation type

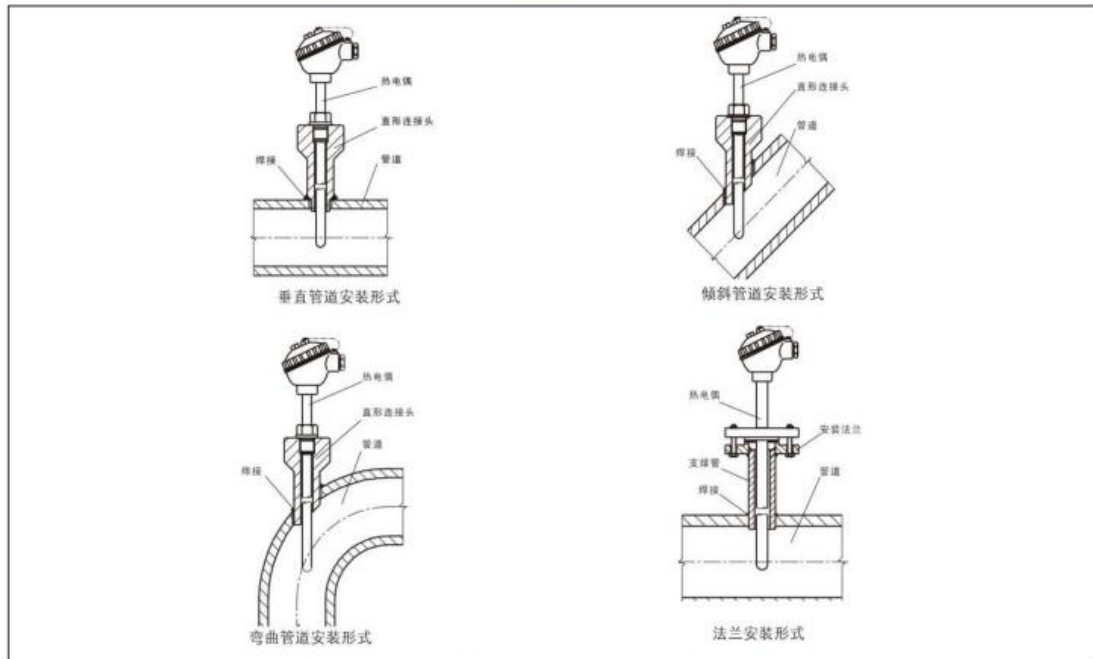

直形接头 Straight joint

代号 Code	M	D	D ₁	D ₂	d	h	H
TH48A	M12×1.5	Φ32	Φ18	Φ12	Φ7	27	60,120
TH48B	M16×1.5	Φ36	Φ18	Φ14	Φ7	27	80
TH48C	M20×1.5	Φ40	Φ18	Φ14	Φ7	27	60
TH48D	M27×2	Φ47	Φ28	Φ22	Φ17	32	60
TH48E	M33×2	Φ55	Φ36	Φ30	Φ21	34	120
TH48F	NPT1/2	Φ39	Φ27	Φ21	Φ16	35	60
TH48G	NPT3/4	Φ47	Φ31	Φ25	Φ20	40	120
TH48H	NPT1	Φ47	Φ41	Φ35	Φ30	45	120



代号 Code	M	D	D ₁	d	h	H
TH49A	M27×2	Φ47	Φ28	Φ18	30	90
TH49B	M33×2	Φ55	Φ36	Φ24	30	150
TH49C	NPT1/2	Φ39	Φ27	Φ16	30	90
TH49D	NPT3/4	Φ47	Φ31	Φ20	35	90
TH49E	NPT1	Φ47	Φ41	Φ30	40	150

