

## 防腐热电阻 Anti-corrosion thermal resistance

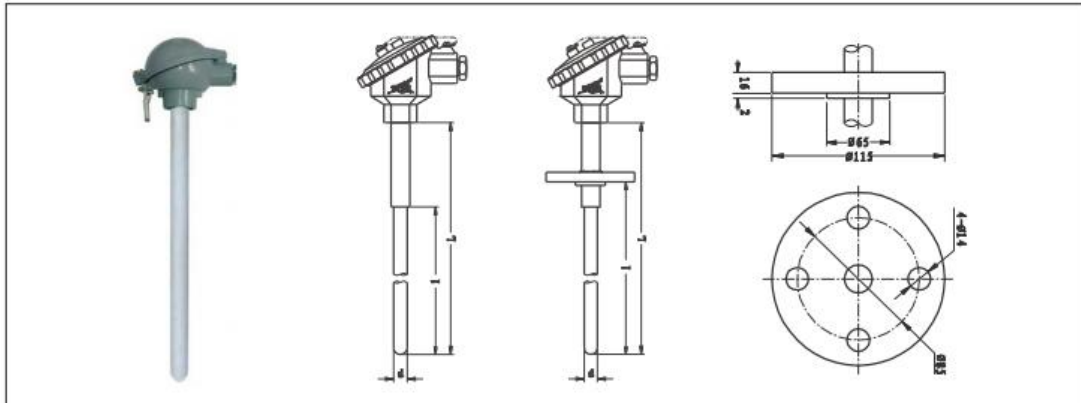

### 应用

采用新型防腐材料，外包覆聚四氟乙烯F46，适用于石油化工各种腐蚀性介质中测温。是氯碱行业的专用测温仪表。

### Application

It adopts the new anti-corrosion materials with PTFE F46 being rapped externally and it is suitable for temperature measurement in all kinds of corrosive medium in petrochemical industry. It is a special temperature-measuring instrument in chlor alkali industry.

### 主要技术参数

电气出口:M20×1.5,NPT11/2  
热响应时间:≤8s  
防护等级:IP65  
防爆等级:dIIBT4.dIICT5

### Main technical parameters

Electrical outlet:M20×1.5,NPT11/2  
Thermal response time:≤8s  
Protection level:IP65  
Explosion-proof grade:dIIBT4.dIICT5

型号 Model	分度号 Graduation	测温范围 °C Range of temperature measurement °C	热响应时间 Thermal response time	保护管材料 Material for protective tube	规格 Specification	
					d	L × 1
WZPF-130 WZP <sub>2</sub> F-130	Pt100	A级 -30-300 B级 -50-500	<80s	1Cr18Ni9Ti	Φ16	300×150 350×200 400×250 450×300 500×350 550×400 600×450 650×500 750×600 1000×850
WZCF-130 WZC <sub>2</sub> F-130	Cu50 Cu100	0~150				
WZPF-430 WZP <sub>2</sub> F-430	Pt100	A级 -30-300 B级 -50-500				
WZCF-430 WZC <sub>2</sub> F-430	Cu50 Cu100	0~150				